

# **Linear and Digital IC Applications**

Subject Code: **(EC502PC)**

Regulations : R16 JNTUH

Class :III Year B.Tech ECE I Semester



**Department of Electronics and communication Engineering**  
**BHARAT INSTITUTE OF ENGINEERING AND TECHNOLOGY**

**Ibrahimpattam -501 510, Hyderabad**

# LINEAR AND DIGITAL IC APPLICATIONS (EC502PC)

## COURSE PLANNER

### I. COURSE OVERVIEW:

Integrated Circuits design can be divided into the broad categories of digital and analog IC design. The physical world is inherently analog indicating that there is always need for analog circuitry. Today the growth of any industry is dependent upon electronics to a great extent. Integrated circuit is electronics and this course IC application acquaints the students with general analog principles and design methodologies using practical devices and applications. It focuses on process of learning about signal condition, signal generation, instrumentation, timing and control using various IC circuitry. With modern digitization advantages we need to work with digital data and hence digital ICs play a crucial role in connecting physical world to the more sophisticated digital world. This course focuses on analysis, design and applications of modern digital integrated circuits.

### II. PREREQUISITE(S):

1. Electronic Devices & Circuits
2. Switching Theory and Logic
3. Electronic Circuit Analysis.

### III: COURSE OBJECTIVES:

1	To introduce the basic building blocks of linear integrated circuits.
2	To teach the linear and non - linear applications of operational amplifiers.
3	To introduce the theory and applications of analog multipliers and PLL
4	To teach the theory of ADC and DAC.
5	To introduce the concepts of waveform generation and introduce some special function ICs.
6	To understand and implement the working of basic digital circuits

### IV: Course Outcomes:

S.No.	Description	Bloom's Taxonomy Level
1	Understand the internal operation of Op-Amp and its specifications.	Knowledge, Understand (Level 1, Level 2)
2	Analyze and design linear applications like adder, subtractor, instrumentation amplifier and etc. using Op-Amp.	Apply, Analyze (Level 3, Level 4)
3	Analyze and design non linear applications like multiplier, comparator and etc, using Op-Amp.	Apply, Analyze (Level 3, Level 4)
4	Classify various active filter configurations based on frequency response and construct using 741 Op-Amp.	Analyze (Level 4)
5	Operate 555 timers in different modes like bistable, monostable and astable operations and study their applications.	Apply, Analyze (Level 3, Level 4)
6	Determine the lock range and capture range of PLL and use in various applications of communications.	Knowledge, Understand (Level 1, Level 2)

### V: HOW PROGRAM OUTCOMES ARE ASSESSED:

PROGRAM OUTCOMES (PO)		Level	Proficiency assessed by
PO1	<b>Engineering knowledge:</b> Apply the knowledge of mathematics, science, engineering fundamentals, and an engineering specialization to the solution of complex engineering problems ( <b>Fundamental Engineering Analysis Skills</b> ).	3	Assignments, Tutorials
PO2	<b>Problem analysis:</b> Identify, formulate, review research literature, and analyze complex engineering problems reaching substantiated conclusions using first principles of mathematics, natural sciences, and engineering sciences( <b>Engineering Problem Solving Skills</b> ).	3	Assignments
PO3	<b>Design/development of solutions:</b> Design solutions for complex engineering problems and design system components or processes that meet the specified needs with appropriate consideration for the public health and safety, and the cultural, societal, and environmental considerations( <b>Social Awareness</b> ).	3	Mini Projects
PO4	<b>Conduct investigations of complex problems:</b> Use research-based knowledge and research methods including design of experiments, analysis and interpretation of data, and synthesis of the information to provide valid conclusions( <b>Creative Skills</b> ).	2	Projects
PO5	<b>Modern tool usage:</b> Create, select, and apply appropriate techniques, resources, and modern engineering and IT tools including prediction and modeling to complex engineering activities with an understanding of the limitations( <b>Software and Hardware Interface</b> ).	3	Projects
PO6	<b>The engineer and society:</b> Apply reasoning informed by the contextual knowledge to assess societal, health, safety, legal and cultural issues and the consequent responsibilities relevant to the professional engineering practice( <b>Social Awareness</b> ).	2	Development of Prototype, Projects
PO7	<b>Environment and sustainability:</b> Understand the impact of the professional engineering solutions in societal and environmental contexts, and demonstrate the knowledge of, and need for sustainable development( <b>Social Awareness</b> ).	3	Oral Discussions
PO8	<b>Ethics:</b> Apply ethical principles and commit to professional ethics and responsibilities and norms of the engineering practice( <b>Professional Integrity</b> ).	1	Inventions and case studies
PO9	<b>Individual and team work:</b> Function effectively as an individual, and as a member or leader in diverse teams, and in multidisciplinary settings ( <b>Team work</b> ).	2	Development of Prototype, Projects
PO10	<b>Communication:</b> Communicate effectively on complex engineering activities with the engineering community and with society at large, such as, being able to comprehend and write effective reports and design documentation, make effective presentations, and give and receive clear instructions( <b>Communication Skills</b> ).	3	Presentations
PO11	<b>Project management and finance:</b> Demonstrate knowledge and understanding of the engineering and management principles and apply these to one's own work, as a member and leader in a team, to manage projects and in multidisciplinary environments ( <b>Practical Engineering Analysis Skills</b> ).	2	Development of Prototype, Projects

PO12	<b>Life-long learning:</b> Recognize the need for, and have the preparation and ability to engage in independent and life-long learning in the broadest context of technological change( <b>Continuing Education Awareness</b> ).	3	Seminars, Discussions
------	---	---	-----------------------

1: Slight (Low) 2: Moderate (Medium) 3: Substantial (High) - : None

#### VI: HOW PROGRAM SPECIFIC OUTCOMES ARE ASSESSED:

	Program Specific Outcomes (PSO)	Level	Proficiency assessed by
PSO1	<b>Professional Skills:</b> An ability to understand the basic concepts in Electronics & Communication Engineering and to apply them to various areas, like Electronics, Communications, Signal processing, VLSI, Embedded systems etc.,in the design and implementation of complex systems.	1	Lectures, Assignments
PSO2	<b>Problem-solving skills:</b> An ability to solve complex Electronics and communication Engineering problems, using latest hardware and software tools, along with analytical skills to arrive cost effective and appropriate solutions.	2	Tutorials
PSO3	<b>Successful career and Entrepreneurship:</b> An understanding of social- awareness & environmental-wisdom along with ethical responsibility to have a successful career and to sustain passion and zeal for real-world applications using optimal resources as an Entrepreneur.	2	Seminars and Projects

1: Slight (Low) 2: Moderate (Medium) 3: Substantial (High) - : None

#### JNTUH SYLLABUS:

##### UNIT-1:

Operational Amplifier: Ideal and Practical Op-Amp, Op-Amp Characteristics, DC and AC Characteristics, Features of 741 Op-Amp, Modes of Operation - Inverting, Non-Inverting, Differential, Instrumentation Amplifier, AC Amplifier, Differentiators and Integrators, Comparators, Schmitt Trigger, Introduction to Voltage Regulators, Features of 723 Regulator, Three Terminal Voltage Regulators.

**UNIT-2:Op-Amp, IC-555 & IC 565 Applications:** Introduction to Active Filters, Characteristics of Band pass, Band reject and All Pass Filters, Analysis of 1st order LPF & HPF Butterworth Filters, Waveform Generators – Triangular, Saw tooth, Square Wave, IC555 Timer -Functional Diagram, Monostable, and Astable Operations, Applications, IC565 PLL – Block Schematic, Description of Individual Blocks, Applications.

##### UNIT-3:

**Data Converters:** Introduction, Basic DAC techniques, Different types of DACs-Weighted resistor DAC, R-2R ladder DAC, Inverted R-2R DAC, Different Types of ADCs - Parallel Comparator Type ADC, Counter Type ADC, Successive Approximation ADC and Dual Slope ADC, DAC and ADC Specifications.

#### **UNIT-4:**

**Digital Integrated Circuits:** Classification of Integrated Circuits, Comparison of Various Logic Families Combinational Logic ICs – Specifications and Applications of TTL-74XX & Code Converters, Decoders, Demultiplexers, LED & LCD Decoders with Drivers, Encoders, Priority Encoders, Multiplexers, Demultiplexers, Priority Generators/Checkers, Parallel Binary Adder/Subtractor, Magnitude Comparators.

**UNIT-5: Sequential Logic IC's and Memories:** Familiarity with commonly available 74XX CMOS 40XX Series ICs – All Types of Flip-flops, Synchronous Counters, Decade Counters, Shift Registers.  
Memories - ROM Architecture, Types of ROMS & Applications, RAM Architecture, Static & Dynamic RAMs.

#### **TEXT BOOKS:**

1. Op-amps & linear ICs- Ramakanth A.Gayakwad, PHI.2003.
2. Digital Fundamentals-Floyd and Jain, Pearson education, 8th edition 2005.

#### **REFERENCE BOOKS:**

1. Linear Integrated Circuits –D. Roy Chowdhury, New Age International (p) Ltd, 2ndEd., 2003.
2. Op Amps and Linear Integrated Circuits-Concepts and Applications James M. Fiore, Cengage Learning/ Jaico, 2009.
3. Operational Amplifiers with Linear Integrated Circuits by K. Lal Kishore – Pearson, 2009.
4. Linear Integrated Circuits and Applications – Salivahanan
5. Modern Digital Electronics – RP Jain – 4/e – MC GRAW HILL EDUCATION, 2010.

#### **GATE SYLLABUS**

**Analog Circuits:** Small Signal Equivalent circuits of diodes, BJTs, MOSFETs and analog CMOS. Simple diode circuits, clipping, clamping, rectifier. Biasing and bias stability of transistor and FET amplifiers. Amplifiers: single-and multi-stage, differential and operational, feedback, and power. Frequency response of amplifiers. Simple op-amp circuits. Filters. Sinusoidal oscillators; criterion for oscillation; single-transistor and op-amp configurations. Function generators and wave-shaping circuits, 555 Timers. Power supplies.

**Digital circuits:** Boolean algebra, minimization of Boolean functions; logic gates; digital IC families (DTL, TTL, ECL, MOS, CMOS). Combinatorial circuits: arithmetic circuits, code converters, multiplexers, decoders, PROMs and PLAs. Sequential circuits: latches and flip-flops, counters and shift-registers. Sample and hold circuits, ADCs, DACs. Semiconductor memories. Microprocessor (8085): architecture, programming, memory and I/O interfacing

#### **IES SYLLABUS**

**ANALOG ELECTRONIC CIRCUITS:** Transistor biasing and stabilization. Small signal analysis. Power amplifiers. Frequency response. Wide banding techniques. Feedback amplifiers. Tuned amplifiers. Oscillators. Rectifiers and power supplies. Op Amp, PLL, other linear integrated circuits and applications. Pulse shaping circuits and waveform generators.

**DIGITAL ELECTRONIC CIRCUITS:** Transistor as a switching element; Boolean algebra, simplification of Boolean functions, Karnaguh map and applications; IC Logic gates and their characteristics; IC logic families : DTL, TTL, ECL, NMOS, PMOS and CMOS gates and their comparison; Combinational logic Circuits; Half adder, Full adder; Digital comparator; Multiplexer Demulti-plexer; ROM an their applications. Flip flops. R-S, J-K, D and T flip-flops; Different types of counters and registers Waveform generators. A/D and D/A converters. Semiconductor memories.

**LESSON PLAN-COURSE SCHEDULE:**

Session	Week	Unit	Topics	Course Learning outcomes	Reference	
1	1	I	Introduction, Classification of IC's,	To Know the basics of IC's and Classification of IC's	T1	
2			IC chip size and circuit complexity,	To Know the sizes of IC's based on the number of Gates	T1	
3			Basic information of Op-Amp IC741 Op-Amp and its features	To Know the Basics of Linear IC OP-AMP and its features	T1	
4			The ideal & practical Operational amplifier	To understand the operation of OP-AMP's	T1	
5			Op-Amp Block diagram	To Study the Block diagram of OP-AMP	T1	
6	2		Op-Amp characteristics -DC	To understand the DC characteristics of OP-AMP's	T1	
7			Op-Amp characteristics - AC	To understand the AC characteristics of OP-AMP's	T1	
8			Inverting Amplifiers	To Understand the Negative F/B	T1	
9	2		Non-inverting Amplifier	To design the Non Inverting amplifier	T1	
10			Differential amplifier	To design the differential amplifier	T1	
11	3		Instrumentation amplifier	To design the Operation of Instrumentation Amplifier	T1	
12			AC amplifier	To design the operation of AC amplifier	T1	
13			Integrator and differentiator	To design integrator, differentiator using op-amp	T1	
14			Schmitt trigger	To design regenerative comparator	T1	
15			Voltage regulators, 723 regulator, 3terminal regulators	To understand the operation of voltage regulators, features	T1	
16		4	II	ACTIVE FILTERS: Introduction, Butterworth filters – 1st order low pass filters	To understand the Operation of First order Butterworth low pass filter and their frequency response	T1
17				1st order high pass filters	To understand the Operation of First order Butterworth Filter	T1
18	Band pass, Band reject and All-pass filters.			To design the operation and frequency response of Band pass, Band reject and all pass filters.	T1	
19	Triangular, saw tooth and Square waveform generators			To design & the operation of Waveform generators.	T1	
20	Introduction to IC 555 timer, Description of functional diagram			To understand the operation of 555 timer		
21	Monostable and Astable operations and applications.			To understand the oscillations using 555 timer.	T1	
22		PLL -Introduction, basic principle, phase detector/comparator	To study the operation of PLL with a Block diagram	T1		

23	5	III	Introduction to data converters	To understand the basics of data converter	T2	
24			Introduction, basic DAC techniques - weighted resistor DAC	To understand the basics of DAC's, and the operation of weighted resistor DAC	T2	
25			R-2R ladder DAC, inverted R-2R DAC	To know the disadvantage of weighted resistor DAC, and the operation of R-2R ladder DAC and Inverted Ladder DAC	T2	
26	6		A to D converters - parallel comparator type ADC, counter type ADC	To know the basics of ADC's, and the operation of Parallel type and Counter type ADC	T2	
27			Successive approximation ADC, Dual slope ADC	To understand the Operation of Successive Approximation type ADC and Dual slope ADC	T2	
28			DAC and ADC Specifications	To study the specifications of DAC's and ADC's	T2	
29	7		IV	Digital integrated circuits and classification	To know the basics of digital integrated circuits and classification	T2
30				comparison of various logic families	To study the comparison of various logic families	T2
31				CMOS logic levels, MOS transistors, Basic CMOS Inverter	To know CMOS logic levels and design of Inverter using CMOS	T2
32	8	NAND AND NOR GATES, CMOS AND-OR-INVERT AND OR-AND-INVERT GATES		To know the operation and design of NAND and NOR gates using CMOS	T2	
33		Implementation of any function using CMOS logic.		To know the procedure for implementing functions using CMOS	T2	
34		74XX ICS: Study of logic gates using 74XX ICs		To know the basics of Logic gates using ICs	T2	
35	9	40XX ICS: Study of logic gates using 40XX ICs		To know the basics of Logic gates using ICs	T2	
36		Four-bit parallel adder(IC 7483), Comparator(IC 7485)		To study Adder and comparator using IC 74XX series	T2	
37		Decoder(IC 74138, IC 74154), BCD-to-7-segment decoder(IC 7447)		To study Decoder using IC 74XX series	T2	
38		Encoder(IC 74147)	To study Encoder using IC 74XX series.	T2		
39		Multiplexer(IC 74151)	To study Multiplexer using IC 74XX series.	T2		
40	9	Demultiplexer (IC 74154).	To study Demultiplexer using IC 74XX series	T2		
41		Priority generators/checkers	To study Priority generators/checkers	T2		
42		Priority generators/checkers	To study parallel binary adder/subtractor, magnitude comparators	T2		
43	9	SEQUENTIAL CIRCUITS USING TTL 74XX ICS:	To study Flip-Flops using IC	T2		

		V	Flip Flops (IC 7474, IC 7473)	74XX series	
44			Shift Registers, Universal Shift Register(IC 74194)	To study Shift registers using IC 74XX series	T2
45			4- bit asynchronous binary counter(IC 7493).	To study Counters using IC 74XX series	T2
46			ROM Architectures and applications	To study memories	T2
47	10		RAM Architectures Static and Dynamic RAMs	To study types of memories and applications	T2

### IX. MAPPING COURSE OUTCOMES LEADING TO THE ACHIEVEMENT OF PROGRAM OUTCOMES AND PROGRAM SPECIFIC OUTCOMES:

Course Outcomes	Program Outcomes												Program Specific Outcomes		
	PO1	PO2	PO3	PO4	PO5	PO6	PO7	PO8	PO9	PO10	PO11	PO12	PSO1	PSO2	PSO3
CO1	2	2	2	2	3	2	2	-	2	2	2	2	1	2	2
CO2	3	3	2	3	2	1	1	-	2	2	2	2	1	2	2
CO3	2	2	3	2	2	2	1	-	3	1	3	3	1	1	2
CO4	3	3	2	3	3	1	2	-	2	2	2	2	1	2	2
CO5	3	3	3	2	2	2	2	-	3	2	3	3	2	2	3
CO6	3	2	3	3	3	2	2	-	3	3	3	3	2	3	2
Average	2.67	2.5	2.5	2.5	2.5	1.67	1.67	-	2.5	2	2.5	2.5	1.33	2	2.17
Average (Rounded)	3	3	3	3	3	2	2	-	3	2	3	3	1	2	2

1: Slight (Low) 2: Moderate (Medium) 3: Substantial (High) -: None

### X. QUESTION BANK: (JNTUH)

#### UNIT I

#### Long Answer Questions:

S. No	Question	Blooms Taxonomy Level	Course Outcome
1	Explain the operation of a Schmitt trigger circuit using IC 741.	Understand	1
2	Explain practical integrator circuit using IC 741.	Analyze	1
3	Explain the internal structure of voltage regulator IC 723. Also draw a low voltage Regulator circuit using IC 723 and explain its operation.	Analyze	2
4	Explain the following terms in an OP-AMP. 1. Input Bias current 2. Input offset voltage 3. Input offset current	Remember	2
5	Explain non inverting comparator using op-amp.	Understand	3
6	Derive the gain for non inverting op-amp.	Remember	2
7	Write a technical note on frequency response characteristics of differential amplifier. State the importance of frequency compensation.	Understand	2
8	What is instrumentation amplifier? What are the required		1

	parameters of an instrumentation amplifier? Explain the working of instrumentation amplifier with neat circuit diagram.	Understand	
9	Explain various DC and AC characteristics of an op.amp. Distinguish between ideal and practical characteristics.	Understand	1
10	With circuit and waveforms explain the application of OPAMP as differentiator and write the advantages of practical differentiator.	Remember	1

### Short Answer Questions:

S. No	Question	Blooms Taxonomy Level	Course Outcome
1	Mention the advantages of integrated circuits.	Remember	1
2	List the applications of IC 741.	Understand	1
3	What is the purpose of IC 741	Understand	1
4	Define an operational amplifier.	Remember	1
5	Mention the characteristics of an ideal op-amp.	Analyze	1
6	Define input offset voltage	Remember	1
7	What are the applications of current sources?	Analyze	1
8	Define sensitivity of an op-amp.	Remember	1
9	What is slew rate? Discuss the methods of improving slew rate.	Understand	1,2
10	Explain pole zero compensation and frequency compensation in op-amp.	Remember	1
11	Define band gap reference? Explain in detail about the reference circuit	Remember	1
12	Briefly explain the method of using constant current bias for increasing CMRR in differential?	Remember	1
13	Explain the operation of a Schmitt trigger circuit.	Analyze	1,2
14	Why do we use $R_{comp}$ resistor?	Understand	1
15	Define thermal drift?	Understand	1
16	Draw the circuit of lossy integrator showing initial conditions?	Analyze	1,2

## UNIT II

### Long Answer Questions:

S. No	Question	Blooms Taxonomy Level	Course Outcome
1	Design a second order low pass filter.	Evaluate	4
2	Draw the circuit of a 1st order low pass filter and derive its	Analyze	4

	transfer function.		
3	Explain the functional block diagram of 555timer.	Evaluate	5
4	Explain working of PLL using appropriate block diagram.	Evaluate	6
5	Draw the block diagram of an Astable multivibrator using 555timer and derive an expression for its frequency of oscillation.	Evaluate	5
6	Draw the block diagram of monostable multivibrator using 555timer and derive an expression for its frequency of oscillation.	Evaluate	5
7	Derive the expression for i) capture range in PLL ii) Lock in range in PLL.	Analyze	6
8	Draw the circuit of a 1st order band pass filter and derive its transfer function.	Analyze	4
9	Draw the circuit of a all pass filter and derive its transfer function.	Analyze	4
10	Derive the voltage to frequency converter factor for VCO.	Analyze	6
11	Explain any two applications of Astable multivibrator using 555IC.	Analyze	5
12	Explain VCO operation in PLL.	Understand	6
13	Explain triangular waveform generator using IC 741	Understand	5
14	Design second order high pass filter.	Evaluate	4
15	Derive the frequency of oscillations in VCO.	Analyze	6

### Short Answer Questions:

S. No	Question	Blooms Taxonomy Level	Course Outcome
1	Why active filters are preferred?	Remember	4
2	What is meant by cut off frequency of a high pass filter and how it is found out in a first order high pass filter	Understand	4
3	List the applications of 555 timer in monostable mode of operation	Remember	5
4	Define 555 IC?	Remember	5
5	List the basic blocks of IC 555 timer?	Remember	5
6	Define VCO.	Remember	6
7	What does u mean by PLL?	Understand	6
8	List the applications of 565 PLL	Apply	6
9	Define lock range in PLL.	Understand	6
10	Define capture range in PLL.	Apply	6
11	Define pull-in time in PLL.	Understand	6

12	Draw a circuit to for converting a square wave into a series of positive pulses.	Understand	5
13	What is the difference between triangular and sawtooth wave.	Understand	5
14	Define an electronic filter.	Remember	4
15	Define pass band and stop band of a filter.	Remember	4

### UNIT III

#### Long Answer Questions:

S. No	Question	Blooms Taxonomy Level	Course Outcome
1	Explain the working of a Weighted resistor D/A converter.	Evaluate	8
2	Explain successive approximation A/D converter.	Understand	8
3	Explain the working of a dual slope A/D converter.	Remember	8
4	With neat diagram, explain the working principle of inverter R-2R ladder DAC.	Understand	8
5	Explain the working of a counter type A/D converter and state it's important feature.	Understand	8
6	Write the specifications of DAC.	Understand	8
7	Write the specifications of ADC.	Analyze	8
8	With neat diagram, explain the working principle of R-2R ladder type DAC.	Analyze	8
9	Explain the operation of parallel comparator type ADC.	Analyze	8
10	Design 4 bit weighted resistor DAC.	Analyze	8

#### Short Answer Questions:

S. No	Question	Blooms Taxonomy Level	Course Outcome
1	Define data converters?	Remember	8
2	Indicate types of data converters.	Remember	8
3	Name the different DAC techniques.	Remember	8
4	Define weighted resistor type DAC.	Understand	8
5	Sketch the 2 bit weighted resistor type DAC.	Understand	8
6	Sketch the 3 bit weighted resistor type DAC.	Understand	8
7	Sketch the 4 bit weighted resistor type DAC.	Understand	8
8	Define R-2R Ladder DAC.	Understand	8
9	Sketch the 2 bit R-2R Ladder DAC.	Understand	8

10	Sketch the 3 bit R-2R Ladder DAC.	Understand	8
11	Sketch the 4 bit R-2R Ladder DAC.	Remember	8
12	Define inverted R-2R DAC.	Understand	8
13	Sketch the 2 bit inverted R-2R DAC.	Understand	8
14	Sketch the 3 bit inverted R-2R DAC.	Understand	8
15	Sketch the 4 bit inverted R-2R DAC.	Understand	8
16	Write the need of data converters.	Understand	8
17	Give applications of data converters.	Understand	8
18	Give the drawbacks of weighted resistor type DAC.	Understand	8
19	Give the advantages of weighted resistor type DAC.	Understand	8
20	Calculate basic step of 9 bit DAC is 10.3 mV. If 000000000 represents 0V, what output produced if the input is 101101111?	Apply	8

#### UNIT IV

#### Long Answer Questions:

S. No	Question	Blooms Taxonomy Level	Course Outcome
1	Explain the following terms with reference to CMOS logic. i. Logic Levels ii. Noise margin iii. Power supply rails iv. Propagation delay	Apply	10
2	Draw the circuit diagram of two-input 10K ECL OR gate and explain its operation.	Analyze	11
3	Design CMOS transistor circuit for 2-input AND gate. Explain the circuit with the help of function table?	Remember	11
4	Draw the resistive model of a CMOS inverter circuit and explain its behavior for LOW and HIGH outputs.	Remember	11
5	Design a three input NAND gate using diode logic and a transistor inverter? Analyze the circuit with the help of transfer characteristics.	Evaluate	11
6	Realize the logic function performed by 74×381 with ROM.	Evaluate	11
7	Explain how to estimate sinking current for low output and sourcing current for high output of CMOS gate.	Apply	11
8	Design combinational circuit for common anode 7 segment display / driver.	Apply	11
9	Design 16 bit adder using two 7483 ICs.	Remember	10
10	Explain sinking current and sourcing current of TTL output? Which of the parameters decide the fan-out and how?	Remember	10

11	Draw and explain the 2 input TTL NOR gate.	Understand	11
12	Draw the CMOS circuit diagram of tri-state buffer. Explain circuit with the help of logic diagram and function table.	Remember	11
12	Draw the circuit for CMOS OR-AND invert logic gates and explain its functioning.	Apply	11
14	Explain the operation of encoders.	Apply	12
15	Explain magnitude comparators.	Apply	12

### Short Answer Questions:

S. No	Question	Blooms Taxonomy Level	Course Outcome
1	Write short notes on MOS transistors.	Remember	9
2	Design CMOS transistor circuit for 2-input AND gate.	Understand	9
3	Explain sourcing current of TTL output?	Remember	9
4	Which of the parameters decide the fan-out and how?	Understand	9
5	Explain sinking current of TTL output?	Understand	10
6	Explain the term Voltage levels for logic '1' & logic '0' with reference to TTL gate.	Understand	10
7	Explain the DC Noise margin with reference to TTL gate?	Understand	10
8	Explain Low-state unit load with reference to TTL gate?	Remember	10
9	Explain High-state fan-out with reference to TTL gate?	Remember	10
10	Explain the use of Package?	Remember	10
11	State the effect of loading CMOS output.	Understand	11
12	Explain with neat diagram interfacing of TTL gate driving CMOS gates.	Remember	11
13	What is combinational logic.	Remember	11
14	Write a short note on priority encoder.	Remember	11
15	What is a multiplexer?	Understand	11

### UNIT V

#### Long Answer Questions:

S. No	Question	Blooms Taxonomy Level	Course Outcome
1	How many ROM bits are required to build a 16-bit adder/subtractor with mode control, carry input, carry output and two's complement overflow out-	Understand	1 3

	put. Show the block schematic with all inputs and outputs.		
2	Draw the basic cell structure of Dynamic RAM. What is the necessity of refresh cycle? Explain the timing requirements of refresh operation.	Analyze	1 3
3	Discuss in detail ROM access mechanism with the help of timing waveforms.	Analyze	1 3
4	Draw the logic diagram of 74×163 binary counter and explain its operation.	Understand	1 3
5	Design a modulo-100 counter using two 74×163 binary counters?	Apply	1 3
6	Design a Modulo-12 ripple counter using 74×74?	Apply	1 3
7	Discuss how PROM, EPROM, EEPROM technologies differ from each other?	Analyze	1 3
8	Differentiate between ripple counter and synchronous counter? Design a 4-bit counter in both modes and estimate the propagation delay.	Remember	1 3
9	Design a modulo-88 counter using 74X163 Ics.	Understand	1 3
10	Draw the logic diagram of 74×163 binary counter and explain its operation.	Remember	1 1

### Short Answer Questions:

S. No	Question	Blooms Taxonomy Level	Course Outcome
1	Define static RAM	Understand	13
2	Define dynamic RAM	Understand	13
3	Classify types of ROMs	Understand	13
4	What is the difference between latch& Flip-Flop, Explain with logic diagram.	Remember	12
5	Explain any one application of SR latch.	Understand	12
6	What is race around condition? How it is avoided?	Remember	12
7	How synchronous counters differ from asynchronous counters?	Understand	12
8	List counter applications.	Understand	12
9	What do you mean by sequential circuit? Explain with the help of block diagram.	Remember	12
10	Draw and explain the working of master slave JK flip-flop.	Understand	12
11	Covert JK flip-flop into T flip-flop.	Understand	12
12	Explain the working of 4 bit asynchronous counter.	Remember	12
13	List the basic types of shift registers interns of data movement.	Understand	12
14	Draw and explain the operation of controlled buffer register.	Understand	12

15	Draw and explain 4 bit Johnson counter.	Remember	12
----	---	----------	----

**OBJECTIVE QUESTIONS:**

**UNIT-1**

1. An Op-amp has \_\_\_\_\_ number of inputs and \_\_\_\_\_ output.
2. Op-amp responds only to the \_\_\_\_\_ between its input voltages.
3. Op-amp does not have \_\_\_\_\_ terminal.
4. An ideal Op-amp has \_\_\_\_\_ open loop gain.
5. The two basic configurations of Op-amp are \_\_\_\_\_ and \_\_\_\_\_
6. The voltage gain of an inverting amplifier is the ratio of \_\_\_\_\_
7. The voltage gain of a non-inverting amplifier is..: \_\_\_\_\_
8. The Ideal voltage transfer curve is a plot between \_\_\_\_\_ and \_\_\_\_\_
9. The gain of an Op-amp with \_\_\_\_\_ is termed as closed loop gain.
10. The bandwidth of ideal operational amplifier is..: \_\_\_\_\_

**UNIT-2**

1. Inverting differential Amplifiers is also called as \_\_\_\_\_
2. Output of summer is \_\_\_\_\_
3. Differentiator can be constructed from \_\_\_\_\_
4. In Voltage follower gain of Op-amp is \_\_\_\_\_
5. Op-amp with diodes are called as \_\_\_\_\_
6. Output of Half-wave rectifier is \_\_\_\_\_
7. Zero crossing detectors is also called as \_\_\_\_\_
8. When Op-amp is used as comparator \_\_\_\_\_
9. Advantages of instrumentation amplifier \_\_\_\_\_
10. Integrator can be constructed from \_\_\_\_\_

**UNIT-3**

1. Multiplexing is the process in which \_\_\_\_\_
2. Multiplexer contains \_\_\_\_\_
3. Sample and Hold circuit \_\_\_\_\_
4. In sample mode, the capacitor Two \_\_\_\_\_
5. Types of converters are \_\_\_\_\_
6. In D/ A converters  $V =$  \_\_\_\_\_
7. In weighted resistor DAC as the number of bits increase \_\_\_\_\_
8. In R-2R Ladder  $V_o =$  \_\_\_\_\_
9. If the input voltage is greater than converter reference voltage then \_\_\_\_\_
10. In A/D converters  $V =$  \_\_\_\_\_

**UNIT-4**

1. Relation between Noise Margin and Propagation delay is -----
2. Multiplexing is the process in which \_\_\_\_\_
3. Multiplexer contains \_\_\_\_\_
4. How many inputs and outputs does a full-adder have?  
 (a) 2 inputs, 2 outputs      (b) 2 inputs, 1 output      (c) 3 inputs, 2 outputs      (d) 2 inputs, 3 outputs
5. How many inputs and outputs does a full-subtract or have?  
 a. 2 inputs, 2 outputs      (b) 2 inputs, 1 output  
 b. 3 inputs, 2 outputs      (d) 2 inputs, 3 outputs
6. A full adder can be realized using:

- A. 1 half-adder, 2 OR gates  
B. 2 half-adders, 2 OR gates
7. Which of the following devices selects one of several inputs and transmits to a single output?  
(a) Decoder (b) Multiplexer (c) Demulti-plexer (d) Counter
8. A combinational logic circuit, which generates a particular binary word or number is  
(a) Decoder. (b) multiplexer (c) Encoder (d) Demulti-plexer
9. Which of the following logic circuits takes data from a single source and distribute it to one of the several output lines.  
(a) Multiplexer (b) Data selector (c) Demulti-plexer (d) Parallel counter
10. A multiplexer is also known as  
(a) Coder (b) Decoder (c) Data selector (d) Multivibrator

### UNIT-5

1. The difference bit output of a half-sub tractor is the same as:  
i. difference bit out of a full-sub tractor  
ii. sum bit output of a half-adder  
iii. sum bit output of a full-adder  
iv. carry bit output of a half-adder
2. How many inputs and outputs does a full-adder have?
3. (a) 2 inputs, 2 outputs (b) 2 inputs, 1 output (c) 3 inputs, 2 outputs (d) 2 inputs, 3 outputs
4. How many inputs and outputs does a full-subtractor have?  
a. 2 inputs, 2 outputs (b) 2 inputs, 1 output  
b. 3 inputs, 2 outputs (d) 2 inputs, 3 outputs
5. A full adder can be realized using:  
a. 1 half-adder, 2 OR gates  
b. 2 half-adders, 2 OR gates
6. Which of the following devices selects one of several inputs and transmits it to a single output?  
(a) Decoder (b) Multiplexer (c) Demultiplexer (d) Counter
7. A demultiplexer is used to  
a. Perform serial to parallel data conversion  
b. Select data from several inputs and route it to a single output  
c. Route the data from a single input to one of the many outputs  
d. Perform parity checking
8. A multiplexer is also known as  
(a) Coder (b) Decoder (c) Data selector (d) Multivibrator
9. Which of the following logic circuits takes data from a single source and distribute it to one of the several output lines?  
(a) Multiplexer (b) Data selector (c) Demultiplexer (d) Parallel counter
10. A combinational logic circuit, which generates a particular binary word or number is  
(a) Decoder. (b) Multiplexer (c) Encoder (d) Demultiplexer

## XI. GATE QUESTIONS:

1. In the figure, if the CMRR of the operational amplifier is 60 dB, then the magnitude of the output voltage is

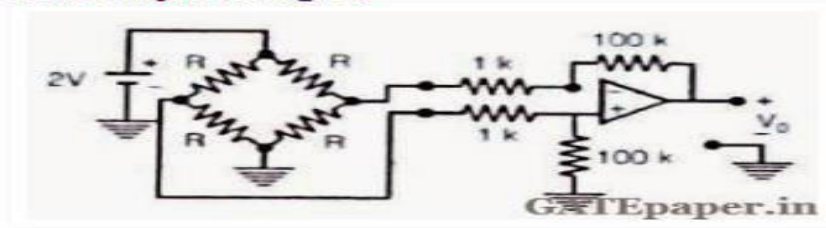

**Answer:** 100 mV

2.

Referring to the figure shown,

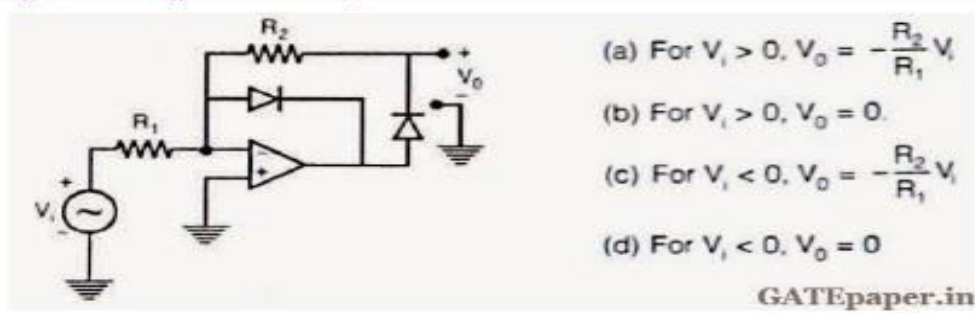

**Answer:** B & C

3.

1. Data can be changed from spatial code to temporal code and vice-versa by using

- ADCs and DACs
- Shift registers
- Synchronous counters
- Timers

**Answer:** Shift registers

2. Match the following ADC's with their Maximum conversion time for 8 bit digital output.

Type of ADC	Maximum conversion for 8 bit ADC in clock cycles.
(a) Successive approximation	(1) 1
(b) Dual slope	(2) 8
(c) Parallel comparator	(3) 16
	(4) 256
	(5) 512

4.

The advantage of using a dual slope ADC in a digital voltmeter is that

- Its conversion time is small
- Its accuracy is high
- It gives output in BCD format
- It does not require a comparator

5.

In a series regulated power supply circuit, the voltage gain  $A_V$  of the pass transistor satisfies the condition

- $A_V \rightarrow \infty$
- $1 \ll A_V < \infty$
- $A_V \equiv 1$
- $A_V \ll 1$

Answer: C

## XII. WEBSITES:

- <https://technicalpublications.org/index.php/ebooks/linear-and-digital-ic-applications.html>
- <http://www.slideshare.net/guest3f9c6b/linear-and-digital-ic-applications-jntu-model-paperwwwstudentyogicom>
- <http://www.linear.com/>
- <http://ecmsnist.weebly.com/linear--digital-ic-applications-ldic.html>
- <http://unowyteyifinoh.j.pl/linear-digital-integrated-circuits-pdf.html>

## XIII. EXPERT DETAILS:

- Sai Pavan Sudha Manager – Ami Tech India Pvt. Ltd.
- P. Raghu Sr. Hardware Engineer – Ami Tech India Pvt. Ltd.
- Pratap Reddy Prof. JNTUH
- Dr. E. Venkat Reddy Prof. BIET

## XIV. JOURNALS:

### INTERNATIONAL

- International Journal of Electronics and Communication Engineering (IJECE)
- International Journal of Electronic Networks, Devices and Fields (IJENDF)
- International Journal of Applied Engineering Research (IJAER)
- International Journal of Electronics Engineering Research (IJEER)
- International Journal of Microcircuits and Electronics(IJME)

### NATIONAL

- Analog Integrated Circuits and Signal Processing
- IETE Journal of Research
- Journal of Electromagnetic Waves and Application
- Journal of VLSI Signal Processing
- Journal of Supercomputing

## XV. LIST OF TOPICS FOR STUDENT SEMINARS

- IC, their types with pin diagram descriptions
- Recent development in IC and the future scope
- Instrumentation amplifiers principle, types and principle

## XVI. CASE STUDIES / SMALL PROJECTS:

- Designing of HALF ADDER using ICs
- Designing of FULL ADDER using ICs
- Designing of MULTIPLEXER using ICs
- Designing of BINARY COUNTER using ICs